

ACTIVITY SHEET

EPISODE 6: LASERS

Practise and consolidate your learning about describing and labelling things by completing our activities.

Activity 1 is based on an actual IELTS listening exercise – you can listen to the associated audio files on your computer at the Study English website:
<http://australianetwork.com/studyenglish/s1476443.htm>

We have also included a transcript of the audio as part of this activity sheet. If you can't listen via computer, read through the listening exercise transcript below.

ACTIVITY 1

Here is a Section 3 excerpt from an IELTS practice listening test. Use the strategies from the study notes to prepare for this listening.

IELTS Practice Listening Test SECTION 3 - Questions 21-30

(A transcript follows this activity otherwise go to the Study English website and listen to the audio on the activities page for this episode)

Questions 21-26

Label the parts of the microwave. Choose words from the box below. There are more words in the box than you will need.

generator	cooking chamber	control section	turntable
magnetron	wavelength	waveguide	Door
interlock system	locking device	solid walls	Fan
high-voltage transformer		electromagnetic waves	

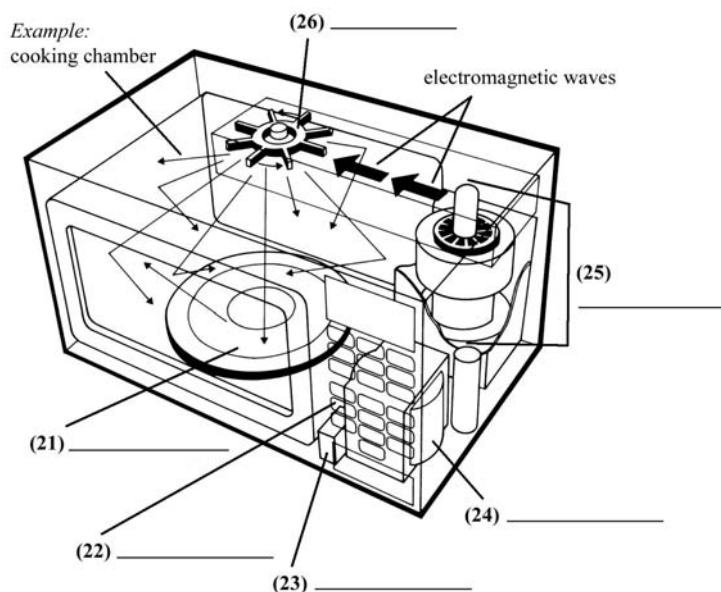

Questions 27-30

Write NO MORE THAN THREE WORDS OR NUMBERS to complete these sentences.

- 27. Who invented the microwave oven? _____
- 28. What year was it invented? _____
- 29. What is the safety warning? _____
- 30. What are the walls of the oven made of? _____

Transcript for Questions 21-26

Narrator: Section three. You will hear a discussion between two students and a teacher. In the first part of the discussion they are talking about the different parts of a microwave oven. First look at questions 21 to 26. Note the example that has been done for you. Listen to the conversation and label the parts of the microwave oven on the diagram. Choose words from the box. There are more words in the box than you will need.

Jane: Hello Dr Roberts, may I start on the project now?

Dr Roberts: Yes, but first let me look at your diagram. That's good Jane. I think you might start by labeling the turntable. It's the round, flat disc inside the oven.

Jane: I've got that. Is Margaret going to come to this lesson? Should we wait for a while?

Dr. Roberts: No, we'll just start. I'm sure she'll be here soon; let's get back to work.

Jane: Dr Roberts what do you call the thing up the top of the diagram, it looks a bit like a fan- is it the wave-guide?

Dr Roberts: No, it's not. You were right to call it a fan. It disperses the electro-magnetic waves through the cooking chamber. Do you see? Now, I think we could label the control section.

Jane: That's the keypad to the right of the door; it's very familiar to everyone because they're the buttons people push to make the microwave oven work. The next thing I'd like to label is the interlock system. It's at the right-hand side of the door, down the bottom.

Dr Roberts: It may be better to say the non-hinged side.

Jane: Okay. It's really important because...

Margaret: Sorry I'm late Dr Roberts. Oh, that's a nice diagram Jane.

Dr Roberts: That's okay Margaret. Jane was discussing the interlock system. Can you show where it is?

Margaret: Down the bottom, near where the door opens. It's like a little box. It stops the oven from making microwaves if the door is opened.

Dr Roberts: That's right. And can you describe the magnetron?

Jane: The magnetron is a small box containing a central stem, surrounded by a hollow cylinder. The cylinder is divided into cavities with magnets around the outside. It's been cut through in the drawings, so you can see it clearly.

Dr Roberts: What's the function of the magnets?

Jane: They create microwaves.

Margaret: Magnets make the electrons flow in a curve, into a sort of expanding spiral and that makes a current of very little waves – *microwaves*.

Jane: It takes a lot of power to do that. There's a high voltage transformer just behind the keypad. It transforms domestic voltage into extremely high voltage. And it converts the current from alternating current to direct current. The electricity from the transformer charges the filament of the magnetron, and electrons jump off it.

Dr Roberts: That's fine. We can leave the drawing now, and concentrate on what you're going to tell the other students.

Transcript for Questions 27-30

Narrator: Look at questions 27 to 30. Write no more than three (3) words or numbers to complete the sentences.

Dr Roberts: The microwave oven is a very useful device. And its inventor, Dr Spencer, was quite surprised when he invented it.

Margaret: Do you spell Spencer with a 'C' or an 'S'?

Dr Roberts: With a 'C.'

Jane: Is it true he was working on something else at the time?

Dr Roberts: Yes. It was in 1945 and Dr Spencer was working on radar. It was quite new then. I'm told he had a chocolate bar in his pocket while he was working on radar, and he was very surprised to find it had melted. That's how we got started on microwaves.

Jane: Did they have many problems when they started to develop microwave technology?

Dr Roberts: The biggest one was a safety issue- working out a way to keep the microwaves in. Finally they came up with the interlock system, which interrupts the power supply if anyone opens the oven too soon- before the time is up. They also added noisy beeps so people would know when the door was opened.

The microwave has metal walls, and they keep the microwaves inside the oven. The amount of metal in the walls is in proportion to the amount of energy the magnetron produces. The microwave oven is certainly a most convenient thing, but not many people know how it works. I think you're nearly ready to talk about it, when you do your presentation.

Narrator: That is the end of section three. You will now have some time to check your answers.

ACTIVITY 2

Choose a colour from the box below which best answers the question.

mauve	white	red	golden	burgundy
green	ginger	crimson	jade	blue

Question 1: Which is a semi-precious or precious stone mostly found in Asia?

Question 2: Which describes a pastel shade?

Question 3: Which describes someone who is envious?

Question 4: Which colour is used to describe someone who has seen a ghost?

Question 5: Which refers to an alcoholic beverage?

Question 6: Which describes the status of being in debt?

Question 7: Which is sometimes used to describe a particular colour of hair?

Question 8: Which describes someone who is depressed?

Question 9: Which describes leaves in autumn?

Question 10: Which is sometimes used to describe the colour of a cat?

ANSWERS ACTIVITY 1

- Question 21: turntable
Question 22: control section
Question 23: interlock system
Question 24: high-voltage transformer
Question 25: magnetron
Question 26: fan
Question 27: (Dr) Spencer
Question 28: 1945
Question 29: noisy beeps
Question 30: metal

ANSWERS ACTIVITY 2

Choose a colour which best answers the question.

Question 1: Which is a semi-precious or precious stone mostly found in Asia?
jade

Question 2: Which describes a pastel shade?
mauve

Question 3: Which describes someone who is envious?
green

Question 4: Which colour is used to describe someone who has seen a ghost?
white

Question 5: Which refers to an alcoholic beverage?
burgundy

Question 6: Which describes the status of being in debt?
red

Question 7: Which is sometimes used to describe a particular colour of hair?
golden

Question 8: Which describes someone who is depressed?
blue

Question 9: Which describes leaves in autumn?
crimson

Question 10: Which is sometimes used to describe the colour of a cat?
ginger